

Lab 5

BPSK – Binary Phase Shift Keying

INTRODUCTION:

Generation of BPSK:

Consider a sinusoidal carrier. If it is modulated by a hi-polar hit stream according to the scheme illustrated in Figure below, its polarity will be reversed every time the bit stream changes polarity. This, for a sinewave, is equivalent to a phase reversal (shift). The multiplier output is a BPSK signal.

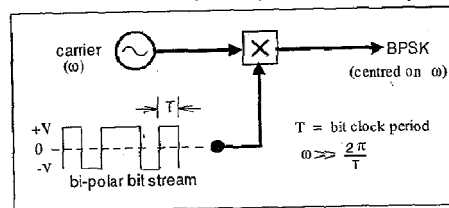

The information about the hit stream is contained in the changes of phase of the transmitted signal. A synchronous demodulator would be sensitive to these phase reversals. The appearance of a BPSK signal in the time domain is shown in below Figure (lower trace). The upper trace is the binary message sequence.

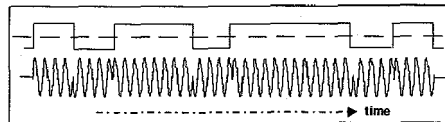

There is something special about the waveform of above Figure. The wave shape is 'symmetrical' at each phase transition. This is because the bit rate is a submultiple of the carrier frequency ($\omega / 2\pi$). In addition, the message transitions have been timed to occur at a zero-crossing of the carrier. Whilst this is referred to as 'special', it is not uncommon in practice. It offers the advantage of simplifying the bit clock recovery from a received signal. Once the carrier has been acquired then the bit clock can be derived by division.

The basic BPSK generated by the simplified arrangement illustrated in 1st figure will have a bandwidth in excess of that considered acceptable for efficient communications. If you can calculate the spectrum of the binary sequence then you know the bandwidth of the BPSK itself. The BPSK signal is a linearly modulated DSB, and so it has a bandwidth twice that of the baseband data signal from which it is derived 2. In practice there would need to be some form of bandwidth control. Bandlimiting can be performed either at baseband or at carrier frequency. It will be performed at baseband in this experiment.

Demodulation of BPSK:

Demodulation of a BPSK signal can be considered a two stage process:

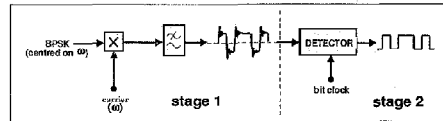

1. Translation back to baseband, with recovery of the bandlimited message waveform
2. Regeneration from the bandlimited waveform back to the binary message bit stream. Translation back to baseband requires a local, synchronized carrier.

Stage 1:

Translation back to baseband is achieved with a synchronous demodulator, This requires a local synchronous carrier. In this experiment a stolen carrier will be used. Carrier acquisition will be investigated in the experiment entitled DPSK – carrier acquisition and BER (within Volume 02 - Further & Advanced Digital Experiments)

Stage 2:

The translation process does not reproduce the original binary sequence, but a bandlimited version of it. The original binary sequence can be regenerated with a detector. This requires information regarding the bit clock rate. If the bit rate is a sub-multiple of the carrier frequency then bit clock regeneration is simplified. In TIMS the DECISION MAKER module can be used for the regenerator, and in this experiment the bit clock will be a submultiple of the carrier.

Phase ambiguity

You will see in the experiment that the sign of the phase of the demodulator carrier is important. Phase ambiguity is a problem in the demodulation of a BPSK signal. There are techniques available to overcome this. One such sends a training sequence, of known format, to enable the receiver to select the desired phase, following which the training sequence is replaced by the normal data (until synchronism is lost !). An alternative technique is to use differential encoding. This will be demonstrated in this experiment by selecting a different code from the LINE-CODE ENCODER.

STEPS:

EXTRA MODULES:

DECISION MAKER, LINE-CODE ENCODER and LINECODE DECODER. A total of two PHASE SHIFTER modules is required,

Generation of BPSK:

1. Patch up the modulator of Figure 5; acquaint yourself with a BPSK signal. Examine the transitions as the phase between bit clock and carrier is altered. Vary the bandwidth of the PRBS with the TUNEABLE LPF. Notice the envelope.

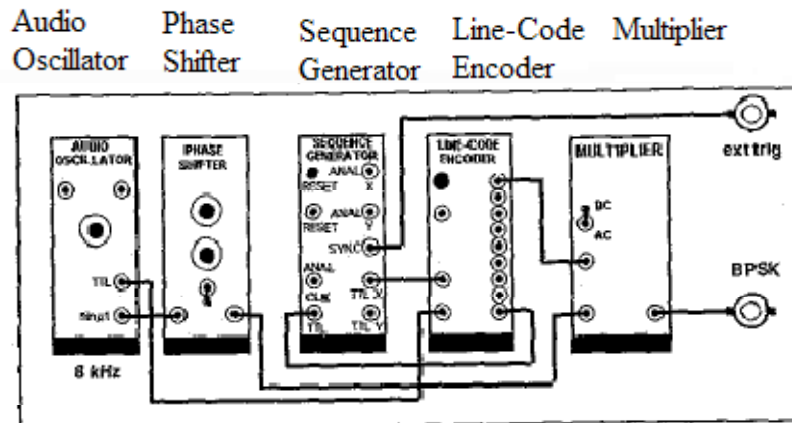

Figure 5: model of the BPSK generator

The AUDIO OSCILLATOR supplies a TTL signal for the bit clock digital DIVIDE-BY-FOUR sub-system in the LINE-CODE ENCODER, and a sinusoidal signal for the carrier.

The PHASE SHIFTER (set to the LO range with the on-board switch SW1) allows relative phase shifts. Watch the phase transitions in the BPSK output signal as this phase is altered. This PHASE SHIFTER can be considered optional.

The digital DIVIDE-BY-FOUR sub-system within the LINE-CODE ENCODER is used for deriving the bit clock as a sub-multiple of the BPSK carrier. Because the DECISION MAKER, used in the receiver, needs to operate in the range about 2 to 4 kHz, the BPSK carrier will be in the range about 8 to 16 kHz.

The NRZ-L code is selected from LINE-CODE ENCODER.

Viewing of the phase reversals of the carrier is simplified because the carrier and binary clock frequencies are harmonically related.

2. Now, you should have two figures. Figure 1: the original signal. Figure 2: the BPSK signal, and describe what you observe.

BPSK demodulation

3. Patch up the demodulator of Figure 6. The received signal will have come from the transmitter of Figure 5 observe the output from the TUNEABLE LPF, and confirm its appearance with respect to that transmitted. If the sequence is inverted then toggle the front panel 180 degree switch of the receiver PHASE CHANGER.

Phase Shifter	Multiplier	Tuneable LPF	Decision Maker	Line-Code Encoder
------------------	------------	-----------------	-------------------	----------------------

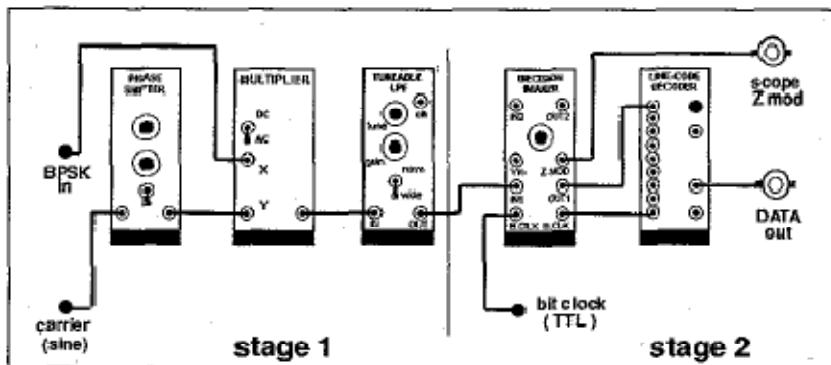

Figure 6: the BPSK demodulator

The phase of the carrier is adjustable with the PHASE SHIFTER for maximum output from the lowpass filter. Phase reversals of 180° can be introduced with the front panel toggle switch.

Select the NRZ-L input to the LINE-CODE DECODER. The LINE-CODE ENCODER and LINE-CODE DECODER modules are not essential in terms of the coding they introduce (since a bi-polar sequence is already available from the SEQUENCE GENERATOR) but they are useful in that they contain the DIVIDE-BY-FOUR sub-systems, which are used to derive the sub-multiple bit clock.

The LPF following the demodulator multiplier is there to remove the components at double the carrier frequency. Its bandwidth can be set to about 12 kHz; although, for maximum signal-to-noise ratio (if measuring bit error rates, for example), something lower would probably be preferred.

4. Set the on-board switch SW 1 of the DECISION MAKER to accept NRZ-L coding. Use the gain control of the TUNEABLE LPF to set the input at about the TMS ANALOG REFERENCE LEVEL of ± 2 volt peak. Adjust the decision point. **Check and print the output as Figure 3 and describe what you observe.**
5. Observe the TTL output from the LINE-CODE DECODER. Confirm that the phase of the receiver carrier (for the NRZ-L line code) is still important. **Check and print the output as Figure 4 and describe what you observe.**
6. Now, you have Figure 3, Figure 4: the demodulated signal vs. the original signal.

ACHIEVEMENTS:

Generation of binary phase shift keyed (BPSK) signal; bandlimiting; synchronous demodulation - phase ambiguities.

Reference: D1-08-4 on Volume D1 Fundamental Digital Experiments

Certification: I hereby certify that performance of the experiment above and the writing of this report was entirely by me (or by me and my lab partner). I understand that if this certification is false, I am in violation of Academic Honesty rules and may be subject to serious penalty in accordance with those rules.

Signature _____ Date _____